

OPTIdrill® DH 40CT

Column gear drilling machine with cross table.

The versatile machine for milling and drilling

Facts that impress in terms of quality, performance and price

- ▶ Heavy, solid cast design
- ▶ Smooth action due to polished gearwheels running in an oil sump
- ▶ Large speed range of 95 - 3 200 rpm
- ▶ Two-stage industrial quality electric motor
- ▶ Generously dimensioned, Solid cross table with precision surface finish, adjustable via 3 hand wheels, includes integrated length scale
- ▶ Adjustable end stops on the cross table
- ▶ Gear head and table are height adjustable
- ▶ Table guideways precisely adjustable via V-ledges
- ▶ Solid baseplate with precision surface finish can be used as a workspace for particularly high workpieces by swivelling out the cross table
- ▶ Right-handed/left-handed rotation
- ▶ Gear head pivots through $\pm 60^\circ$
- ▶ Drilling depth stop
- ▶ Thread tapping function



Technical specifications, accessories and dimensions



Model	DH 40CT
Article no.	3034350
Technical data	
Electrical connection	400 V / 3 Ph ~ 50 Hz
Motor output, 2 stages	1.1 / 1.5 kW
Drilling/milling output	
Drilling performance in steel (S235JR)	Ø 32 mm
Continuous drilling performance in steel (S235JR)	Ø 25 mm
Max. sensor head size	Ø 76 mm
Max. shaft milling cutter size	Ø 25 mm
Thread tapping steel (S235JR)	M16
Spindle	
Spindle sleeve stroke	120 mm
Spindle seat	MT 4
Throat	280 mm
Spindle sleeve diameter	75 mm
Draw-in rod	M16
Drilling/milling head	
Rotating drilling table / Swivel range	360° / ± 45°
Spindle speeds	95 - 3 200 rpm
Speeds	2 x 6 speeds
Cross table	
Length x width	730 x 210 mm
T-Slot size / no / distance	14 mm / 3 / 63 mm
Load bearing capacity	50 kg
Clearance spindle to cross table	max. 600 mm
X-axis travel stroke manual	480 mm
Y-axis travel stroke manual	180 mm
Z-axis travel stroke manual	560 mm
Machine base	
Machine base work area L x W	495 x 375 mm
T-slot size / spacing / count	14 mm / 230 mm / 2
Distance spindle - machine base	920 - 1 180 mm
Dimensions	
Column diameter	Ø 115 mm
Length x width x height	1 060 x 745 x 2 090 mm
Weight	350 kg

Accessories	Article no.
Assortment of clamping tools size 12, 58-parts	3352017
Hold-down device 14 mm/M12	3352031
Parallel shim set, 20-part	3354001
Height-adjustable tailstock RST 1	3356155
Horizontal-vertical rotary indexing table RT 150	3356150
Universal coolant unit	3352002

› More „Accessories for drills“ from page 64

Machine vices	Article no.
BMS 120	3000012
BSI 100	3000210
BSI 140	3000214
BSI-Q 100	3000230
BSI-Q 140	3000234

› Information on the vises on page 71

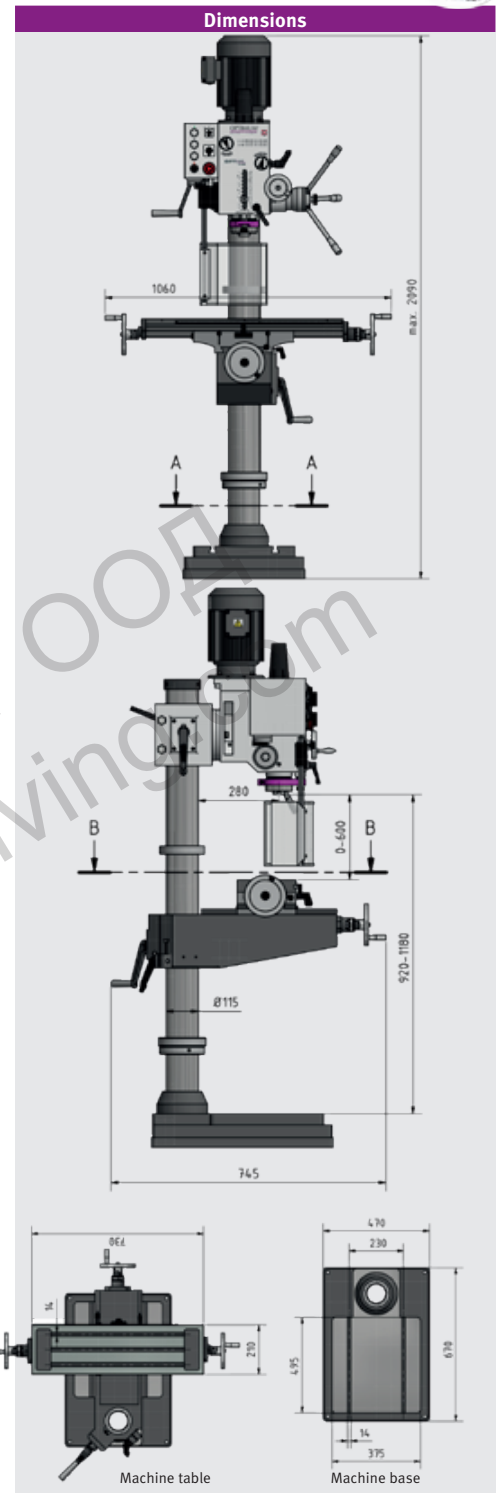

Scope of supply

- › Key type drill chuck 1 - 13 mm / B18
- › T-slot nuts
- › Push-out tools large and small
- › Reduction sleeve MT 4 - MT 3
- › Arbor for drill chuck MT 4 / B16
- › Operating tool